

Low Oil Controller Installation and Operations Manual

CS-105-552-SS07-A2 P/N 174383 552 Enclosure



Table of Contents

| | | |
|---|------------------------------|---|
| 1 | System Layout | 3 |
| 2 | Installation Recommendations | 4 |
| 3 | Connection Instructions | 5 |
| 4 | Connection Diagram | 6 |
| 5 | Operation Instructions | 7 |

Bosch Rexroth Canada Corp. reserves the right to revise this information at any time and for any reason and reserves the right to make changes at any time, without notice or obligation, to any of the information contained in this piece of literature.

Please check for updates at: www.boschrexroth.ca/compu-spread

1 System Layout

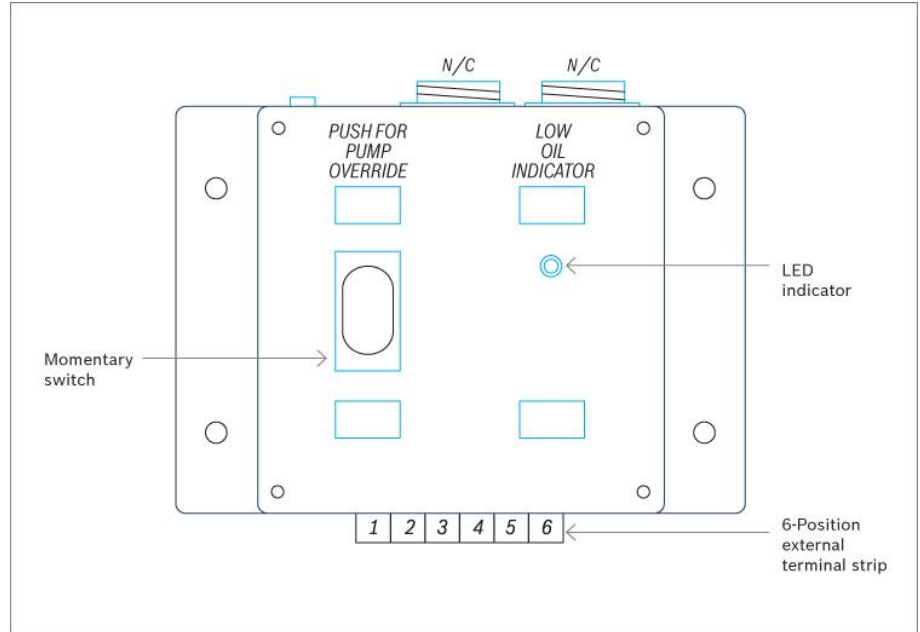

N/C: No Connection.

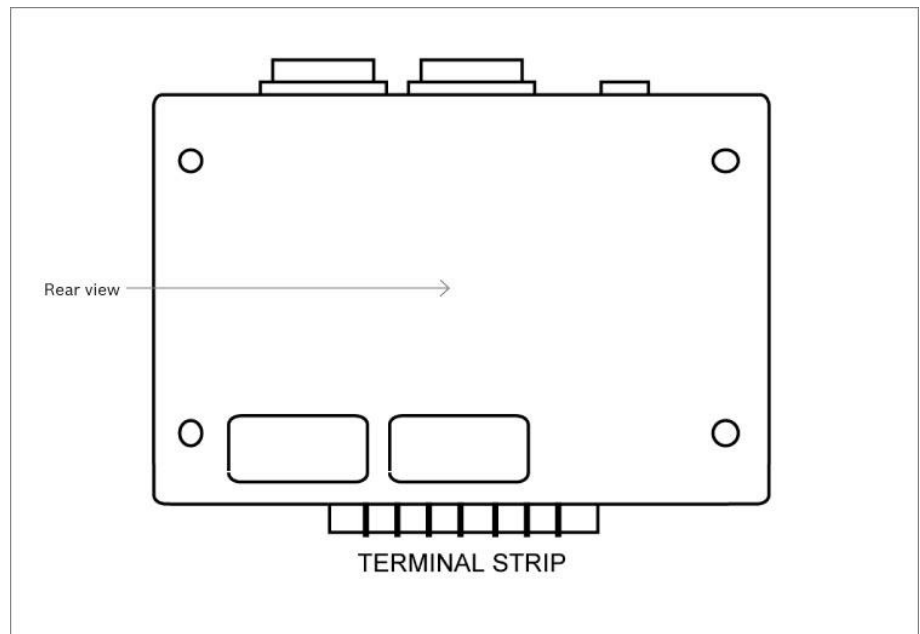

2 Installation Recommendations

1. Read the power float hydraulics manual before starting the installation.
2. Unpack all the supplied parts and check the packing list for completeness.
3. Untie and layout all the cables supplied to ensure proper lengths.
Note: Electromagnetic devices:
Devices such as relays, magnetic switches and solenoids, can generate large negative voltage spikes. These large spikes are conducted into the vehicle's electrical system and may adversely affect all electronic devices including engine computers. It is strongly recommended that these electromagnetic devices be electrically suppressed. See warnings and instructions in Body Builder manuals.
4. Connect the Controller 12V power supply and the ground wire using a dedicated circuit only (directly to the battery).
5. Connect 12V power and ground for all peripheral equipment such as GPS, Material Detection etc., to the same dedicated circuit only.
6. Ensure wiring for transmission devices such as radios, etc. are not attached to the controller or bundled with the controller wiring.
7. Disconnect the battery terminals before welding on a vehicle with electronic equipment.
8. Disconnect the negative battery terminal when wiring electronic devices
9. Mount the consoles so that they do not interfere with vehicle controls or obstruct visibility.
10. Route cables so that they will not be abused or damaged.
11. When routing cables through metal opening, always use grommets to prevent cable damage.
12. When running wires around a dump box pivot point, ensure no connectors can be separated when the hoist is activated.
13. Tie wrap cables clear of all moving parts like drive-axles or conveyor chains.
14. Observe the cable labeling for the proper termination of inputs and outputs.
15. Use dielectric grease on all external cable connections and pins to ensure proper corrosion protection.
16. Thoroughly clean all power and ground terminals before connecting power harness.
17. Stand clear of any hydraulic functions when first powering up the system.
18. DO NOT drill holes in any of the enclosures.
19. DO NOT attempt to mount components onto the sides, top or front of the console.
20. DO NOT attempt to re-wire any of the consoles.

Failure to follow the recommendations will void your warranty.

3 Connection Instructions

| Terminal Strip Position | Function |
|-------------------------|---|
| 1 | Connect low oil input from low oil level switch here. |
| 2 | Connect low oil valve solenoid output here. |
| 3 | Connect battery or chassis ground here. Connect ground to low oil valve solenoid, or pto solenoid here. |
| 4 | Connect 12V input from fuse panel here. Connect 12V to low oil level switch here. |
| 5 | Connect pto solenoid output here (if applicable). |
| 6 | |

Note: Position 3 must be grounded to chassis along with solenoid.

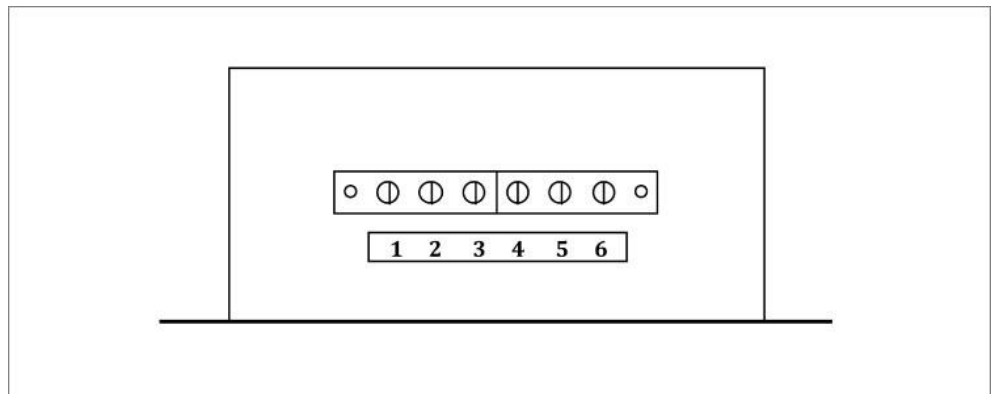

4 Connection Diagram

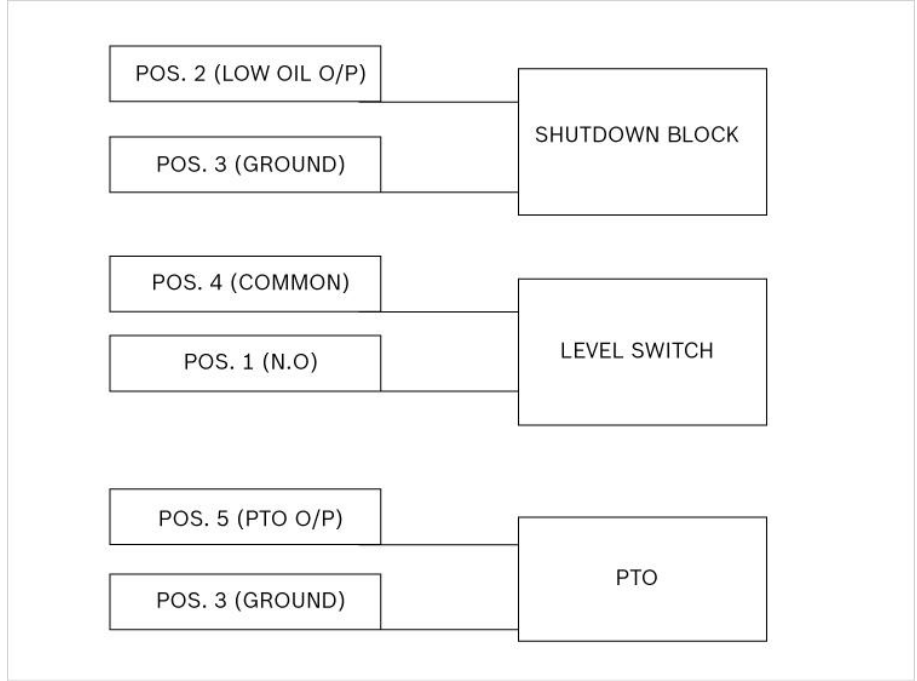

N.O: Normally Open

I/P: INPUT

O/P: OUTPUT

5 Operation Instructions

1. The low oil level switch sends 12V to position 1 on the terminal strip of the low oil controller when it senses low oil pressure.
2. The low oil indicator on the console will light up to indicate that.
3. The low oil controller will send a signal to the shutdown block through position 2 (pump override output).
4. You may override the low oil status by pushing the low oil override switch and holding it down.
5. To stop overriding, release the low oil override switch.

Notes: